

Features

- Double Shell Design to Ensure Low outside Furnace Temperature.
- High Performance Ceramic Fiber Board Lining
- Fast Heat up and Energy Efficiency
- Extended Life/ High Temperature Accuracy Thermocouple-B Type (Platinum- Rhodium)
- Control Console Displays Power Output, Working Voltage and Current.
- Various models are available ranging from 1200°C to 1800°C of heating capacity (having different sizes)
- Provision of different type of Thermocouple is also available

Technical Specification

- Heating Chamber Size - 6"W x 6"H x 6"D
- Controller: 30 Segments Programmable Controller
- *Industrial Grade Molybdenum Disilicide (MoSi₂) Heating Element Size - 6/12 mm
- *For High Purity Elements,
- From 3-4 Liters
- Thermocouple - B Type Pt20Rh/Pt40Rh, (Platinum – Rhodium)
- Max. Heating Rate: 10 - 15°C/minute depending on load volume
- Max. Continuous Operating Temperature: 1700°C
- Uniformity at 1700°C +/- 5 °C
- Temperature Control: **Yudian** Temperature Controller
- 1 Program, 30 segments
- +/- 1 °C temperature accuracy.
- B type thermocouple installed for immediate use. Eurotherm Nanodac Controller/Recorder Facility
- N₂/Ar Purge Kit-Argon Purge Kit
- Motor Driven Forced Exhaust Port.
- Extra B type Thermocouple and Temp. Controller for Over temperature. Control Will shut the Power Off when Furnace Temperature exceeds the preset temperature.
- Eurotherm Controller, (upgrade to multiple program capacity and/or Computer Communication Capability).
- Eurotherm Nanodac with Recording Capabilities,10/50 Programs,100 Segments Safety Sensor Indicator (If temperature exceeds preset temperature in the control system light indicator comes on.)
- Power: 4 KW
- Voltage: 208/240 V – Single Phase
- Net Weight: 110Kgs (242 lbs)
- Overall Dimensions: 19"(W) x 28"(H) x19" (D)
- Warranty: Limited One Year on Electronic Parts

CROMTECH INDIA

1st Floor Begum Niwas, Opp Mercantile, Bank Society Colony, 5th Natwar Nagar Road, Jogeshwari (East), Mumbai 400 060. Maharashtra - India.

Mobile: +91 98693 82134 / 81088 13320

Telefax: +91 22 2838 6028

Email: cromamumbai@mail.com/cromtechindia@mail.com/info@cromtechindia.com/sales@cromtechindia.com

Website: www.cromtechindia.com



Recorder/Controller Specification Sheet

- Secure data recording
- 2 PID control loops
- Dual programmer
- High accuracy universal inputs
- USB removable datastorage facility
- Compact design
- 50MB flash memory
- Ethernet communications
- ¼ VGA crystal clear display
- 30 virtual channels
- Steriliser Application Block
- Relative Humidity Application Block
- Multiple I/O options
- Cascade with auto-tune
- Multi-language support (French, German, Italian and Spanish)

The nanodac™ recorder/controller offers the ultimate in graphical recording combined with PID control for a box of its size. The compact ¼ DIN panel mount unit offers four high accuracy universal inputs for data recording and PID control. This secure data recording device with accurate control is enhanced by a full colour, ¼ VGA display to bring a crystal clear operator interface to even the smallest of machines.

Crystal clear, colour display

The 3.5" TFT display offers incredibly clear visualisation of process parameters with a wide selection of configurable views to best suit the application. Views include: Horizontal and vertical trends, Horizontal and vertical bar graphs, Numeric, Alarm panel, Alarm status, and control loops. The unit also provides user wiring from the front of the product for detailed configuration without the need to connect to a PC.

Data Acquisition and Recording

The nanodac recording functionality utilises the secure strategies and UHH format developed by Eurotherm through years of recording expertise. As well as multiple real-time views and historical review on the product, multiple data archiving strategies are provided utilising the 50MB onboard Flash memory, removable USB and data transfer via FTP to a specified server.

The four universal input channels provide high accuracy (suitable for use in Nadcap applications) and 125ms parallel sampling. An additional 30 virtual channels can be utilised to provide maths, counter, slave communications and totaliser functionality within the instrument.

PID Control Loops

The nanodac instrument can also provide up to three independent control loops (optional). This control functionality utilises the advanced Eurotherm PID algorithm providing high performance and reliability to your process. Functionality includes one of the best autotune facilities available along with overshoot inhibition (cutbacks); compensation for power fluctuations using power feedforward; linear, fan, oil and water cooling.

Heat Treatment is one of the many processes that often need to vary the set-point of the control process over a set period of time; this is achieved by using a set-point program. The nanodac offers an optional Dual Programmer supporting up to 100 programs locally, each program supporting 25 segments. The nanodac also provides remote access to a further 100 programs that can be easily retrieved via FTP or USB memory stick.

imagine bigger better smaller

Specification

General

General	
I/O types	Analogue i/p: Four/eight Digital i/p: Two
	Digital (logic) o/p: Two max (see order code)
	Relay o/p: Four max (see order code)
	DC output: Three max (see order code)
Features:	ModbusTCP master/slave (optional) USB configuration save/restore User linearisation tables (four) Two control loops (optional) Zirconia probe support (optional) 30 Virtual channels (each configurable as counter, maths, totaliser or comms input) Steriliser (optional) Relative humidity (optional) Customised start up screen EtherNet/IP* client/server (optional)

Environmental performance

Ambient temperature range	
	Operating: 0 to 55 °C Storage: -20 to +70 °C
Humidity range	Operating: 5% to 85% RH non condensing Storage: 5% to 85% RH non condensing
Protection	Front panel IP65 Front panel washdown: IP66, NEMA4X (International) Behind panel: IP10 (International)
	Shock/Vibration: To BS EN61131-2 (5 to 150 Hz. at 1g; 1 octave per min.) <2000 metres
Altitude:	<2000 metres
Atmosphere:	Not suitable for use in explosive or corrosive atmospheres
Electrical safety:	BS EN61010-1 (Installation category II; Pollution degree 2)
Electromagnetic compatibility	
Emissions (Standard units):	BS EN61326 Class B - Light industrial
(Low voltage option):	BS EN61326 Class A - Heavy industrial
Immunity:	BS EN61326 Industrial

Other approvals and compliance details

General: CE and cUL, EN61010	
PV input: AMS2750D compliant	
RoHS	EU; China
Packaging:	BS61131-2 section 2.1.3.3.

Physical

Panel mounting:	1/4 DIN
Weight:	Instrument only: 0.44kg (15.52ozs)
Panel cutout dimension:	92 mm x 92 mm (both -0.0 +0.8) or 3.62 in x 3.62 in (both -0.00 +0.03 in)
Depth behind panel:	90 mm (3.54 in) excluding wiring

Operator interface

Display:	3.5" TFT colour display (320 pixels wide x 240 pixels high)
Controls:	Four navigation pushbuttons below the display screen (Page, Scroll, Lower and Raise)

Power requirements

Supply voltage:	Standard: 100 to 230V ac $\pm 15\%$ at 48 to 62Hz Low voltage: 24V ac (+10% -15%) at 48 to 62Hz, or 24V dc (+20% -15%)
Power dissipation:	9W (max.)
Fuse type:	No internal fuse fitted
Interrupt protection:	Standard: Holdup >10ms at 85V RMS supply voltage Low voltage: Holdup >10ms at 20.4V RMS supply voltage

Battery backup

Stored data:	Time, date
Replacement period:	Three years typical
Clock (real-time clock) data:	
	Support time: Minimum of 1 year with unit unpowered
	Temperature stability: 0 to 55 °C $\leq \pm 3.5$ ppm
	RTC Aging: First year to 10 year $\leq \pm 5$ ppm
Type:	Poly-carbonmonofluoride/lithium (BR2330) (PA260195)
Replace battery with Panasonic BR2330/BE only. Use of another battery may present a risk of fire or explosion. See owners manual for safety instructions.	

Caution Battery may explode if mistreated. Do not recharge, disassemble or dispose of in fire.

Ethernet communications

Type:	10/100baseT Ethernet (IEEE802.3)
Protocols:	Modbus TCP/IP master/slave, EtherNet/IP client/server
Cable type:	Category 5
Maximum length:	100metres (110 yards)
Termination:	RJ45. Green LED illuminated = link connected; Amber LED flashing shows link activity

USB port

Number of ports:	One at rear of instrument
Standard:	USB1.1
Transmission speeds:	1.5MBit/sec (low speed device)
Maximum current:	<100mA
Peripherals supported:	Memory stick (8GB max), Bar code reader, QWERTY keyboard

Update/Archive rates

Sample rate (input/output):	8Hz
Trend update:	8Hz max.
Archive sample value:	Latest value at archive time
Display value:	Latest value at display update time

Analogue Input

General	
Number of Inputs:	Four/eight
Input types:	dc Volts, dc mV, dc mA, dual mA (external shunt required), dual mV, dual TC†, Thermocouple, RTD (2-wire and 3-wire), Digital (Contact closure)
Input type mix:	Freely configurable
Sample rate:	8Hz (125ms) 4Hz (250ms) if dual input enabled
Conversion method:	16 bit delta sigma
Input ranges:	See Table 1 and Table 2
Mains rejection (48 to 62Hz)	Series mode: > 95dB Common mode: >179dB
Common mode voltage:	250V ac max.
Series mode voltage:	280mV at lowest range; 5V peak to peak at highest range
Input Impedance:	40mV, 80mV, 2V ranges > 100M Ω ; 62.5k Ω for input voltages > 5.6V 667k Ω for input ranges < 5.6V

Overvoltage protection

Continuous:	± 30 V RMS
Transient (<1ms):	± 200 V pk-pk between terminals
Sensor break detection Type:	ac sensor break on each input giving quick response with no associated dc errors
Recognition time:	<3 seconds
Minimum break resistance:	40mV, 80mV ranges: 5k Ω ; other ranges: 12.5k Ω
Shunt (mA inputs only):	1 Ω to 1K Ω mounted externally
additional error due to shunt:	0.1% of Input
Isolation:	

Channel to Channel: 300V RMS or dc (Double insulation)
Note: If Dual Channel mode enabled primary and secondary inputs are not electrically isolated from each other.

Channel to common electronics: 300V RMS or dc (Double insulation)
Channel to ground: 300V RMS or dc (Double insulation)
Dielectric strength Test: BS EN61010, 1 minute type test
Channel to Channel: 2500V ac
Channel to Ground: 1500V ac

Low Range	High Range	Resolution	Maximum error (Instrument at 25 °C)	Temperature Performance
-40mV	40mV	1.9 μ V	4.6 μ V + 0.053% of reading	13ppm of input per °C
-80mV	80mV	3.2 μ V	7.5 μ V + 0.052% of reading	13ppm of input per °C
-2V	2V	82 μ V	420 μ V + 0.044% of reading	13ppm of input per °C
-3V	10V	500 μ V	1.5mV + 0.063% of reading	45ppm of input per °C

Table 1 Voltage input ranges

Note: Restricted to 2000mV if dual input mode enabled

Resistance input ranges

Temperature scale:	ITS90
Types, ranges and accuracies:	See Table 3
Maximum source current:	200 μ A
Pt100 figures	Range: 0 to 400 Ω (-200 to +850 °C) Resolution: 0.05 °C Calibration error: ± 0.31 °C $\pm 0.023\%$ of measurement in °C at 25 °C ambient

Temperature coefficient: $\pm 0.01^\circ\text{C}/^\circ\text{C}$ $\pm 25\text{ppm}/^\circ\text{C}$ measurement in $^\circ\text{C}$ from 25°C ambient
 Measurement noise: 0.05°C peak-peak with 1.6s input filter
 Linearity error: 0.0033% (best fit straight line)
 Lead resistance: 0 to 22Ω matched lead resistances
 Bulb current: $200\mu\text{A}$ nominal

Low Range	High Range	Resolution	Maximum error (Instrument at 25°C)	Temperature Performance
0Ω	400Ω	$20\text{m}\Omega$	$120\text{m}\Omega + 0.023\%$ of reading	25ppm of input per $^\circ\text{C}$

Table 2 Ohms (RTD) input ranges

RTD Type	Overall range ($^\circ\text{C}$)	Standard	Max. linearisation error
Cu10	-20 to +400	General Electric Co.	0.02°C
Cu53	-70 to +200	RC21-4-1966	0.01°C
JPT100	-220 to +630	JIS C1604:1989	0.01°C
Ni100	-60 to +250	DIN43760:1987	0.01°C
Ni120	-50 to +170	DIN43760:1987	0.01°C
Pt100	-200 to +850	IEC751	0.01°C
Pt100A	-200 to +600	Eurotherm Recorders SA	0.09°C

Table 3 RTD type details

Thermocouple data

Temperature scale: ITS90
 CJC Types: Off, internal, external, remote.
 Remote CJC source: Any input channel
 Internal CJC error: $<1^\circ\text{C}$ max., with instrument at 25°C
 Internal CJC rejection ratio: 40:1 from 25°C
 Upscale/downscale drive: High, low or none independently configurable for each channel's sensor break detection
 Types, ranges and accuracies: See Table 4

T/C Type	Overall range ($^\circ\text{C}$)	Standard	Max. linearisation error
B	0 to +1820	IEC584.1	0 to $400^\circ\text{C} = 1.7^\circ\text{C}$ 400 to $1820^\circ\text{C} = 0.03^\circ\text{C}$
C	0 to +2300	Hoskins	0.12°C
D	0 to +2495	Hoskins	0.08°C
E	-270 to +1000	IEC584.1	0.03°C
G2	0 to +2315	Hoskins	0.07°C
J	-210 to +1200	IEC584.1	0.02°C
K	-270 to +1372	IEC584.1	0.04°C
L	-200 to +900	DIN43710:1985 (to IPT568)	0.02°C
N	-270 to +1300	IEC584.1	0.04°C
R	-50 to +1768	IEC584.1	0.04°C
S	-50 to +1768	IEC584.1	0.04°C
T	-270 to +400	IEC584.1	0.02°C
U	-200 to +600	DIN43710:1985	0.08°C
NiMo/NiCo	-50 to +1410	ASTM E1751-95	0.06°C
Platinel	0 to +1370	Engelhard	0.02°C
Mi/NiMo	0 to +1406	Ipsen	0.14°C
Pt20%Rh/Pt40%Rh	0 to +1888	ASTM E1751-95	0.07°C

Table 4 Thermocouple types, ranges and accuracies

Relay and Logic I/O

O/P1, O/P2 and O/P3 logic I/O and relay specification

Active (current on) current sourcing logic output (O/P1 or O/P2 only)

Voltage o/p across terminals: $+11\text{V}$ min.; $+13\text{V}$ max.
 Short circuit output current: 6mA min. (steady state); 44mA max. (switch current)

Inactive (current off) current sourcing logic output (O/P1 or O/P2 only)

Voltage output across terminals: 0V (min.); 300mV (max.)
 Output source leakage current into short circuit: $0\mu\text{A}$ (min.); $100\mu\text{A}$ (max.)

Active (current on) contact closure sourcing logic input (O/P1 only)

Input current Input at 12V : 0mA (min.); 44mA (max.)
 Input at 0V : 6mA min. (steady state); 44mA max. (switch current)

Open circuit input voltage: 11V (min.); 13V (max.)
 Open circuit (inactive) resistance: 500Ω (min.); ∞ (max.)
 Closed circuit (active) resistance: 0Ω (min.); 150Ω (max.)

Relay Contacts

Contact switching power (resistive): Max. 2A at 230V RMS $\pm 15\%$
 Min. 100mA at 12V
 Current through terminals: 2A

Digital Inputs

Dig InA and Dig InB contact closure logic input

Contact closure

Short circuit sensing current (source): 5.5mA (min.); 6.5mA (max.)
 Open circuit (inactive) resistance: 600Ω (min.); ∞ (max.)
 Closed circuit (active) resistance: 0Ω (min.); 300Ω (max.)

DC Output (option)

O/P1, O/P2, O/P3 DC analogue outputs

Current outputs (O/P1, O/P2 and O/P3)

Output ranges: Configurable within 0 to 20mA
 Load resistance: 500Ω max.
 Calibration accuracy: $<\pm 100\mu\text{A}$ $\pm 1\%$ of reading

Voltage outputs (O/P3 only)

Output ranges: Configurable within 0- 10V
 Load resistance: 500Ω min.
 Calibration accuracy: $<\pm 50\text{mV}$ $\pm 1\%$ of reading

General

Isolation: 300V ac double insulated from instrument and other I/O
 Resolution: >11 bits
 Thermal drift: $<100\text{ppm}/^\circ\text{C}$

* Consult Factory
 † Refer to Manual

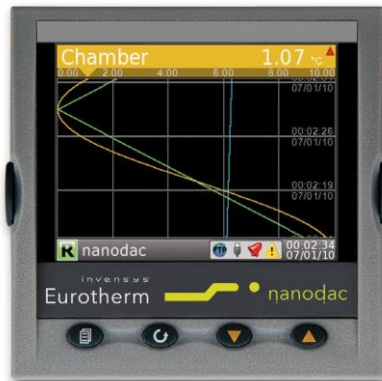

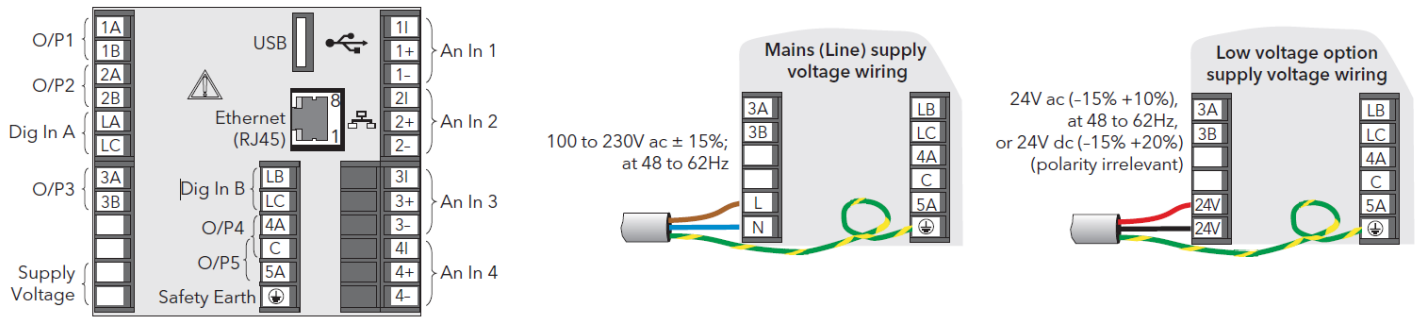

Termination details

The screw terminals accept wire sizes in the range:

Single wire 0.205 to 2.08mm² (14 to 24 AWG) 2 wires 0.205 to 1.31mm² (16 to 24 AWG) inclusive.

Screw terminals should be tightened to a torque not exceeding 0.4Nm (3.54 lb in).

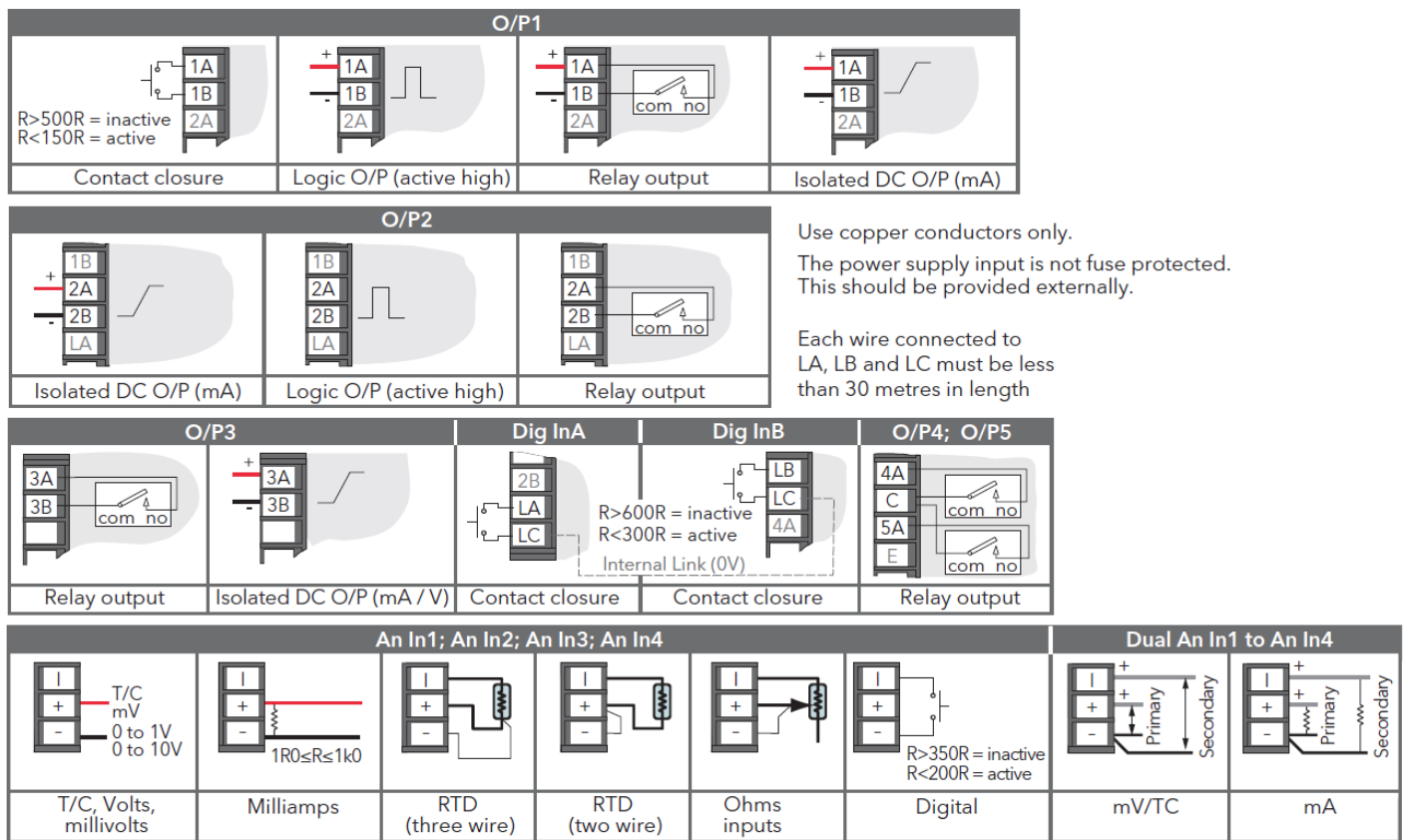

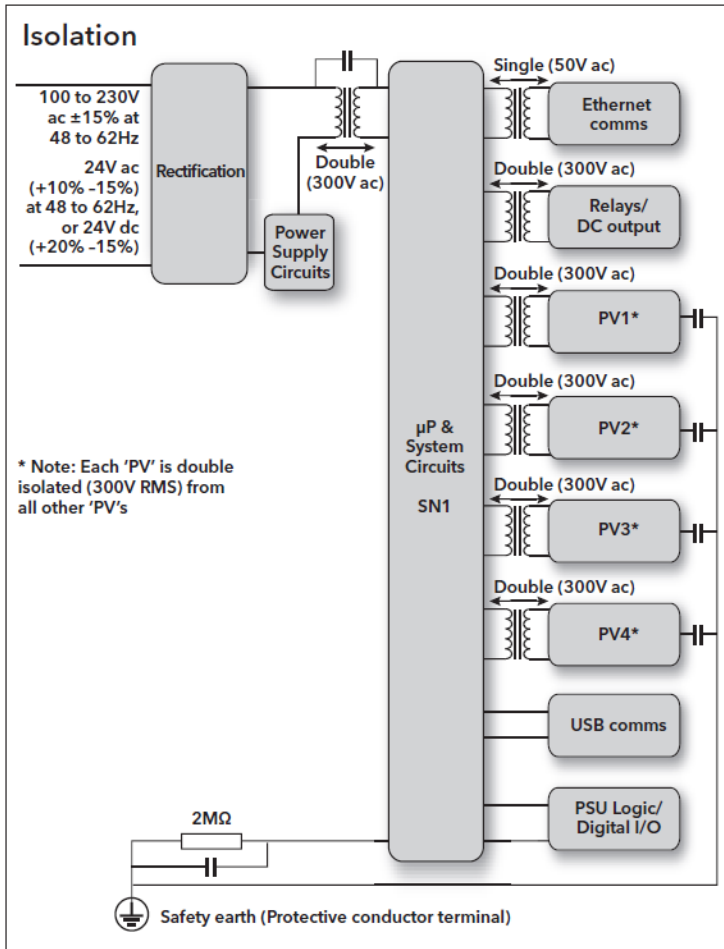

Installation

